

Convey-LINK

Automatic conveying
accessory for **EffiBOT**





Convey-LINK

Convey-LINK, a conveying accessory for **EffiBOT**, automatically transfers your parcels, bins or pallets between your fixed and mobile conveyors.

A **triple security** is ensured by the **bi-directional infrared communication** between the mobile **EffiBOT** conveyor and the fixed conveyor. It guarantees the **precise docking** of the robot, their **compatibility** (dimensions, speed of the rollers) and the **synchronization** of the rollers between conveyors.

Use **EffiBOT** with **Convey-LINK** to interconnect all your fixed conveyors.





The Convey-LINK accessory

- **Convey-LINK** is an accessory that can be attached to the standard **EffiBOT** robot tray. It consists of a set of motorized rollers and **two infrared transmitters and receivers**.
- The **LINK** box, installed on the fixed conveyor, is also equipped with **infrared transmitters and receivers**, compatible with those of **Convey-LINK**.
- **EffiBOT**, in stand-alone mode, docks in front of a fixed conveyor. **Convey-LINK** communicates with the fixed conveyor via **LINK** using **infrared coded signals** to check **compatibility** and **available space** before transfer.

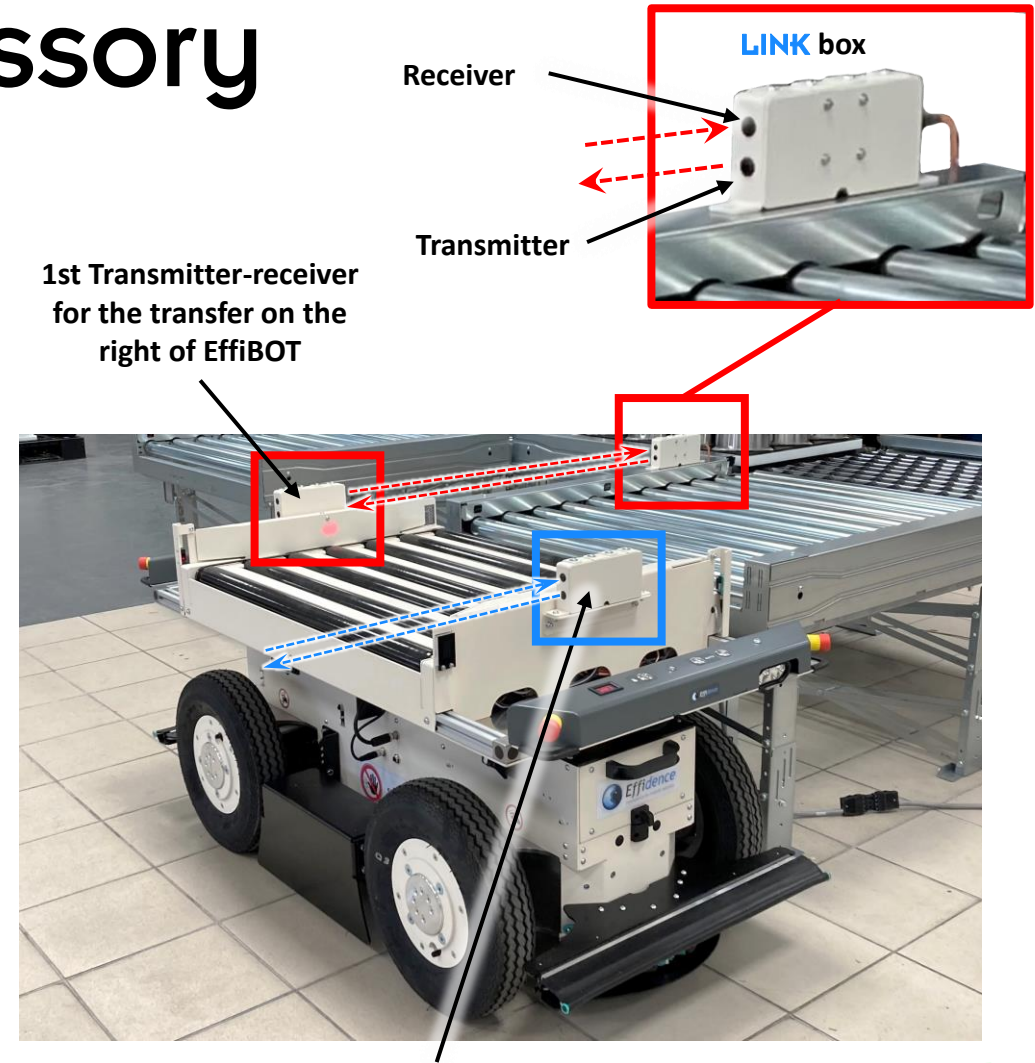

2nd Transmitter-receiver
for the transfer on the
left of EffiBOT





The Convey-LINK accessory

- A central sensor (**detection cell**) detects the presence or absence of a load on **Convey-LINK**.
- On both sides of the **Convey-LINK** there is an immaterial barrier.
- During a package transfer, the light curtain on the fixed conveyor side controls the **complete transfer** of the package. **EffiBOT** is not allowed to move as long as a package is present between the two conveyors.
- The other barrier prevents any risk of falling. It also ensures **centering** during loading.
- To transfer a load, **Convey-LINK** & **LINK** trigger their conveyor rollers simultaneously.

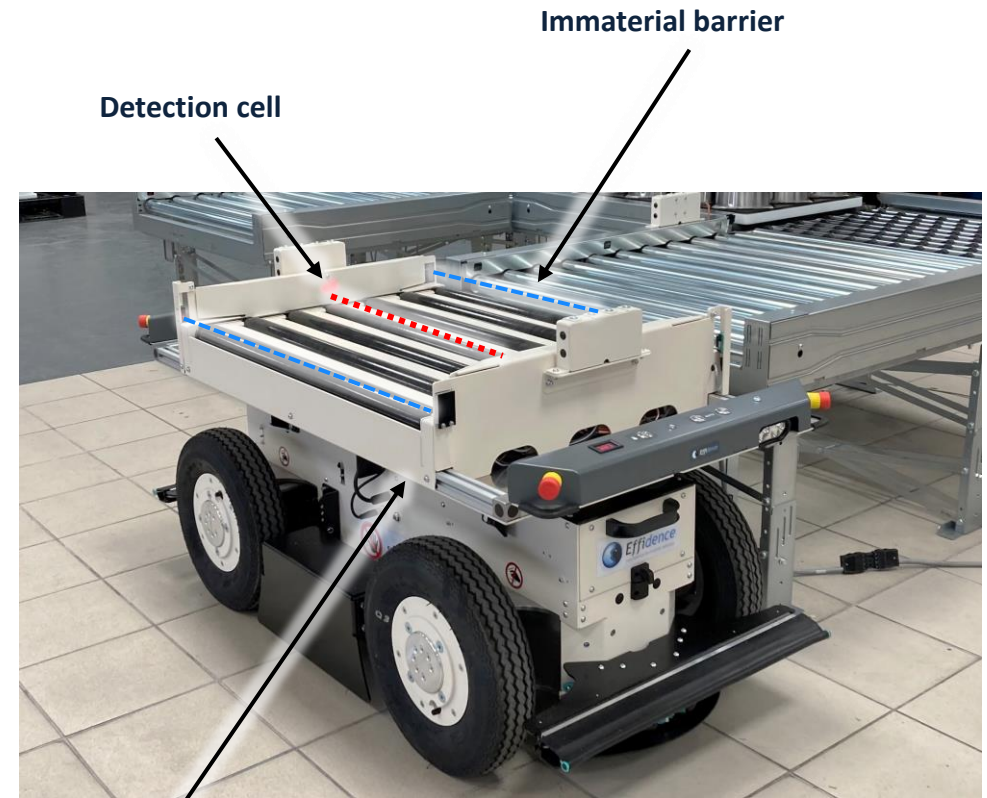

Immaterial barrier





The Convey-LINK accessory

Convey-LINK is available in **different versions**: simply define the useful length of the package to be transported.

Convey-LINK is **modular**. Create your own configuration by installing **1, 2 or 3 independent mobile conveyors** on **EffiBOT**.

Examples of some versions:

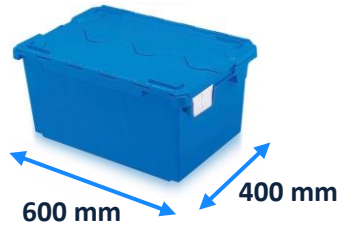

400 version

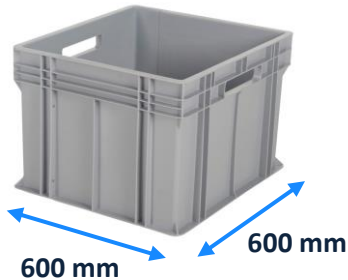

600 version

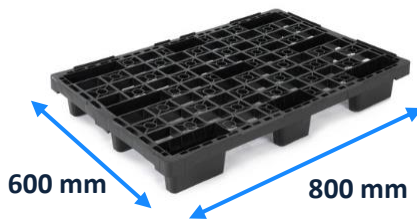

800 version

Compatibility:

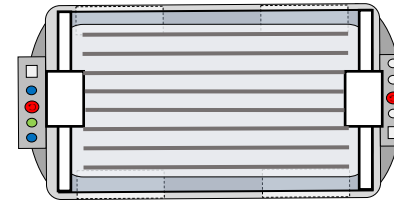

- 400 / 500 / 600 / 800 version

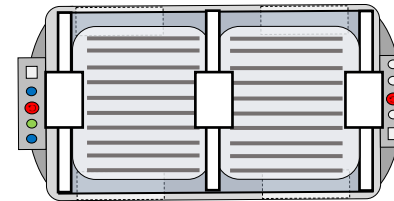

- 400 / 500 / 600 version

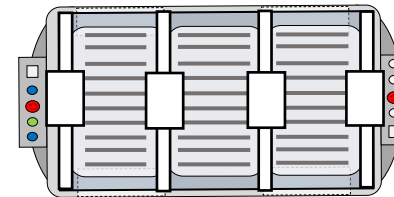

- 400 / 500 version





The Convey-LINK technology

- The **Convey-LINK** technology answers simultaneously the 5 following challenges :

	Convey-LINK 
Securing the docking phase (alignment)	✓
Checking the compatibility of the conveyors	✓
Smooth and instantaneous transfer by synchronizing the rollers	✓
Lateral transfer on both sides of the robot	✓
Flexibility of the solution, up to 3 independent conveyors	✓





The Convey-LINK technology

Securing the docking phase (alignment)



- Only when the **EffiBOT** is precisely aligned (linearly and angularly) with the fixed conveyor, will the infrared beams of **Convey-LINK** and **LINK** be aligned face to face. If the beams are not aligned, communication is impossible, which prevents the transfer of packages.

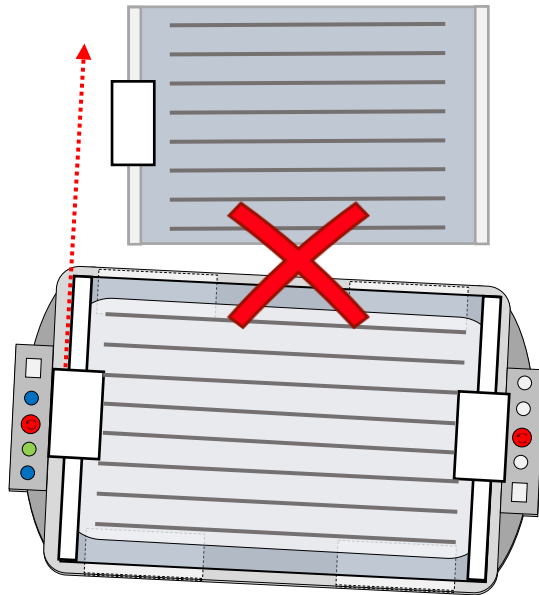

Incorrect docking detection. Transfer of packages prohibited.

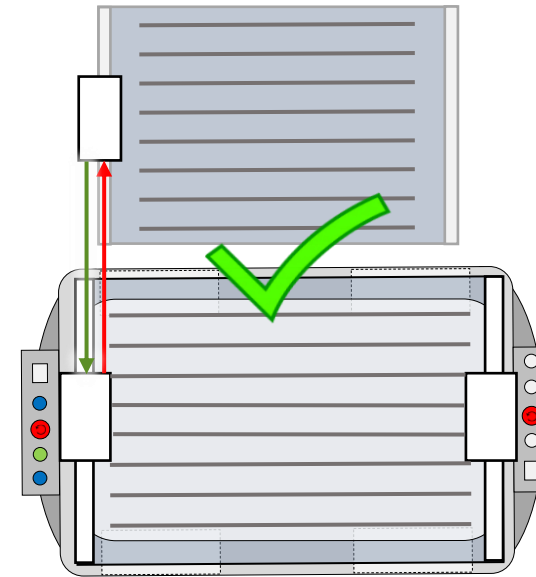

Accurate docking + Operational two-way communication.





The Convey-LINK technology

Checking the compatibility of the conveyors



- After the robot docks, the conveyors communicate with each other by **infrared signals** to check themselves in terms of **dimensions, roller speed, available space ...**

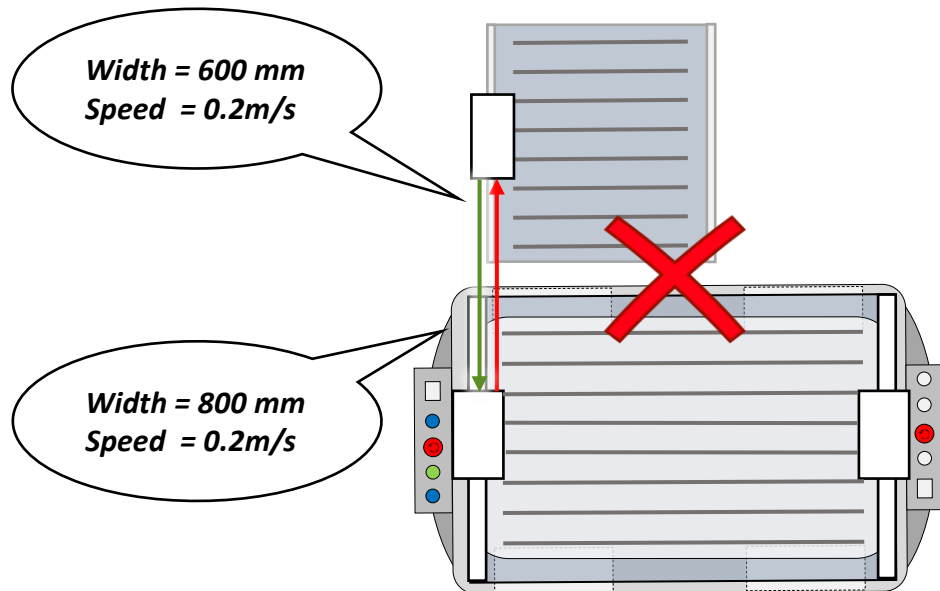

Incompatibility of conveyors. Transfer of packages prohibited

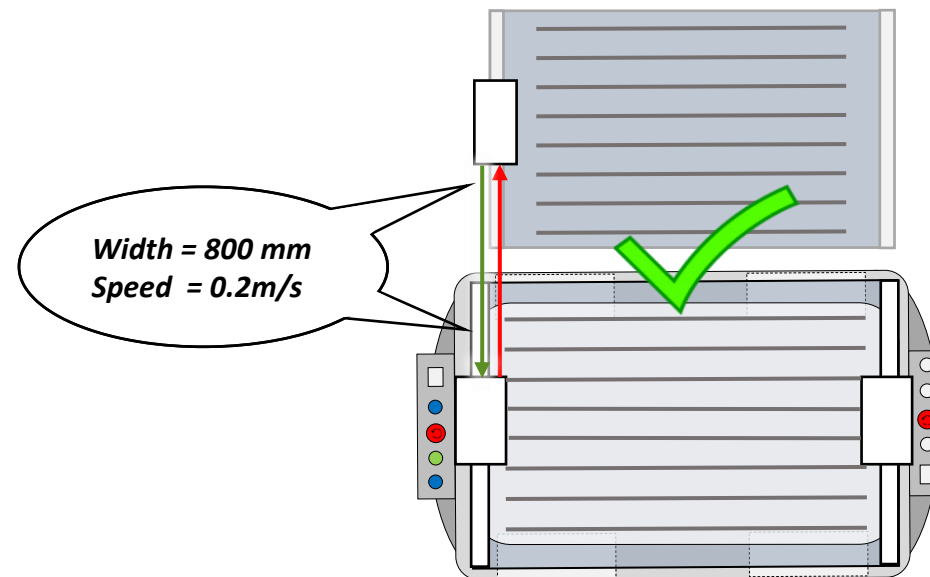

Compatible conveyors. Authorized transfer





The Convey-LINK technology

Smooth and instantaneous transfer by synchronizing the rollers



- The **direct and instantaneous** communication between the fixed conveyor and **Convey-LINK** offers a perfect **synchronization** of the conveyors ensuring a fluid and fast transfer of the packages without risk of falls or blockages.

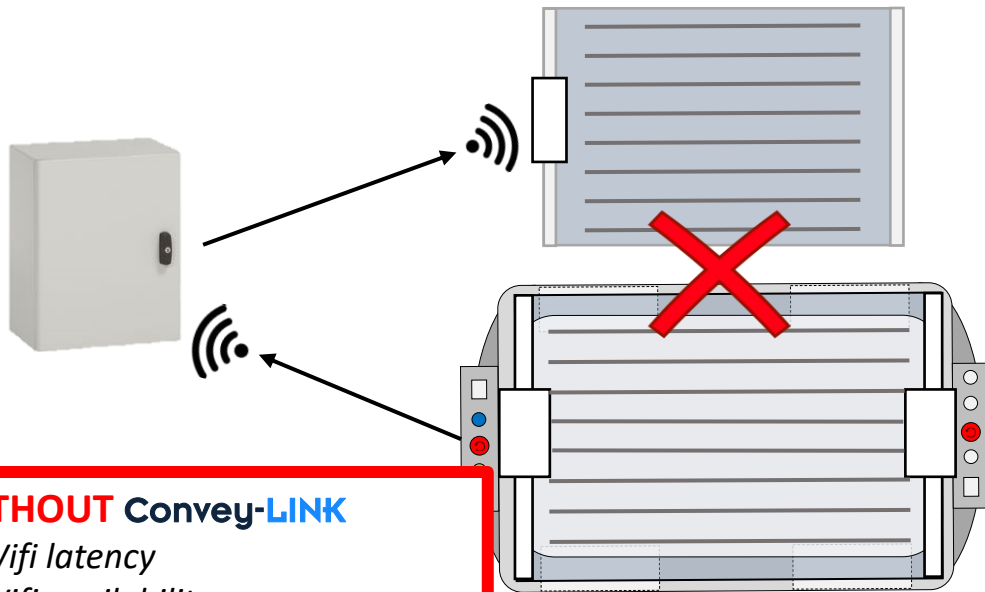

WITHOUT Convey-LINK
- Wifi latency
- Wifi availability

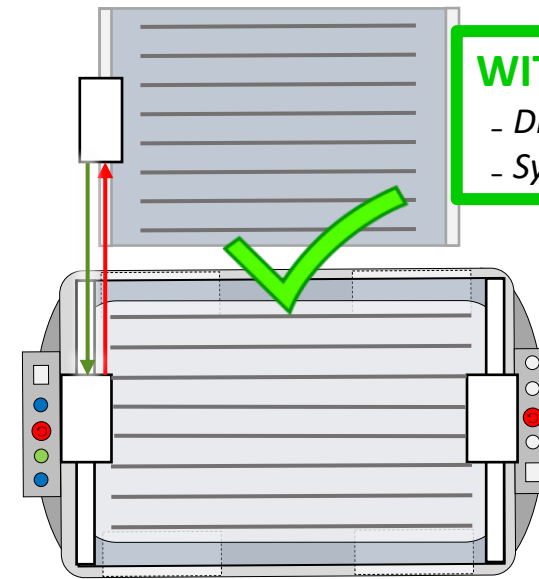

WITH Convey-LINK
- Direct and local communication
- Synchronized conveyors





The Convey-LINK technology

Lateral transfer on both sides of the robot



- Thanks to its symmetry, **Convey-LINK** ensures the **lateral transfer** of packages on **both sides** of the robot, in **forward or reverse motion**.

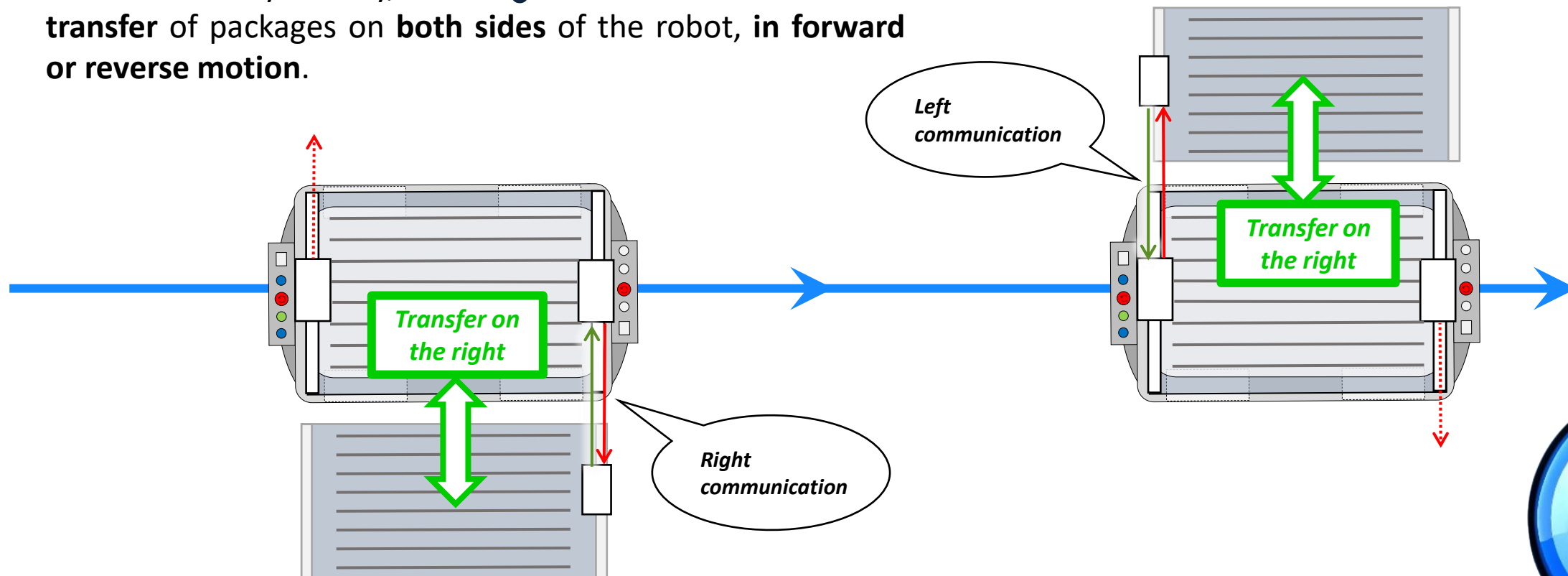



The Convey-LINK technology

Flexibility of the solution, up to 3 independent conveyors

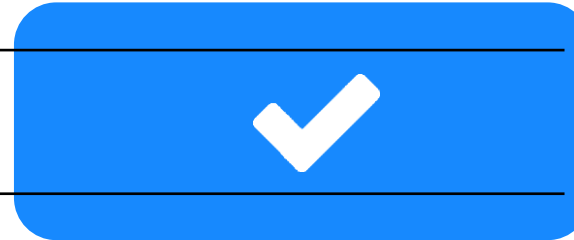

- Install up to **3 independent Convey-LINK** conveyors on **EffiBOT** for maximum productivity and flexibility.

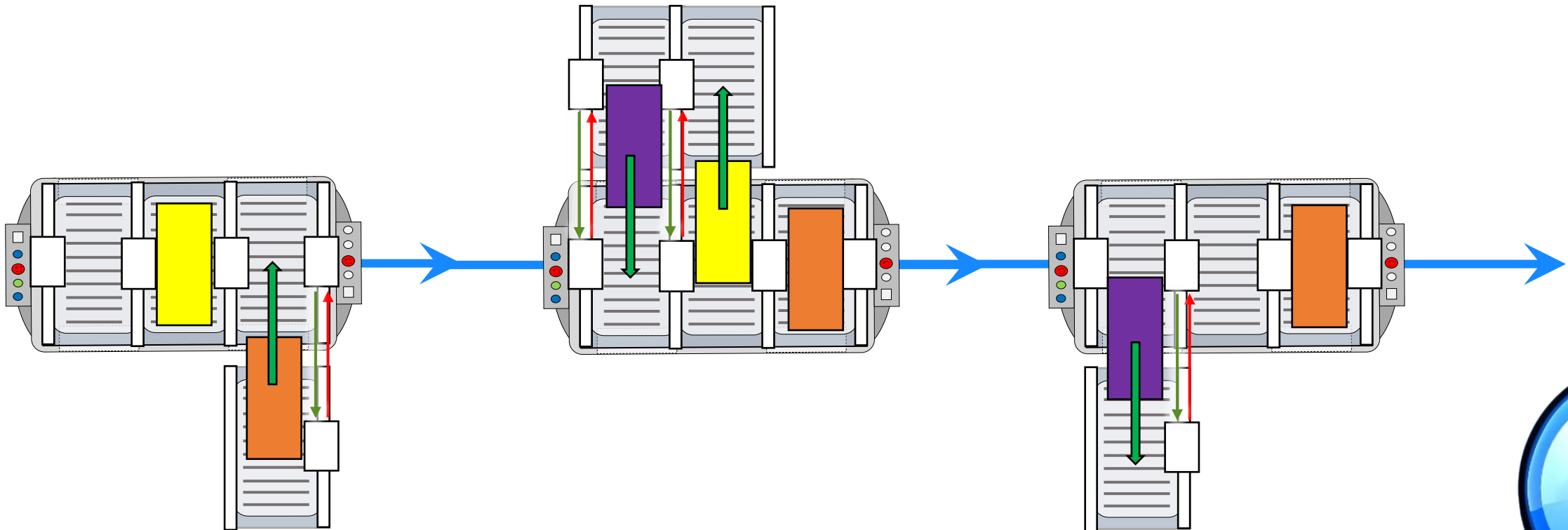





Usage

- **Convey-LINK** can be used **with** or **without** a **fleet server**.
- Without a server: "**standalone mode**", **EffiBOT** moves in total autonomy according to the indications given in its cartography:
 - list of routes,
 - The position of the fixed conveyors and the side on which to dock,
 - Navigation destination defined by zones and activated either by pressing the "Auto" button on the console or triggered by a timer.
 - **Ex:** When the robot picks up a parcel, it always unloads it at the same destination in an autonomous way.
- With a server "**FCS mode**", **EffiBOT** moves in total autonomy according to the instructions communicated in Wifi by the server. Eventually, these instructions can come from the cartography.



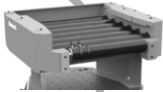

Synthesis

		Other Products 	Convey-LINK 
Loading surface		300 x 300 mm 406 x 356 mm 600 x 400 mm	400 x 600 mm 600 x 600 mm 600 x 1200 mm
Payload - speed		80 kg – 1,35 m/s 50 kg – 1,5 m/s	Jusqu'à 250 kg – 1,7 m/s
Sécurité	Securing the docking phase (alignment)	✗	✓
	Checking the compatibility of conveyors and available space	✗	✓
	Instant and local synchronization of conveyors	✗	✓
Productivité	Lateral transfer on both sides of the robot	✗	✓
	Modularity	YES : 1 conveyor	YES : up to 3 independant conveyors





Convey-LINK

